

Linking System design creates secure joints even on uneven ground - over kerbs, up slopes and across rough terrain. Unlocked or locked mode configurations prevent unauthorised dismantling.

Complies with **BS 7818** Specification for pedestrian restraint systems making it ideal for event management and pedestrian control usage. Advertising signage and reflective material can be fixed to the front and back .

- ◆ 2.0 Meters Long
- ◆ Positive Linking System for Uneven Ground
- ◆ Moulded in 1 Piece from High Impact HDPE
- ◆ Conforms to all relevant Chapter 8 Regulations
- ◆ Can Stack 35 Units per Pallet
- ◆ Total Weight 12.50Kgs
- ◆ Reflectivity to BS873D2
- ◆ Standard Colour – Orange
- ◆ Corporate Identity Available
- ◆ Swivel Feet for Easy Storage
- ◆ Warning Lamps can be Fitted
- ◆ Other Colours Available (minimum order 70 units)

Lifting & Handling Solutions for the Construction Industry
Designed & Manufactured in the UK

Conquip Industrial, Waterbrook Estate, Waterbrook Road, Alton, Hampshire, GU34 2UD. United Kingdom
Telephone: +44 (0) 845 201 5030 **Fax:** +44 (0) 845 201 5031 **E-Mail:** sales@conquipindustrial.co.uk

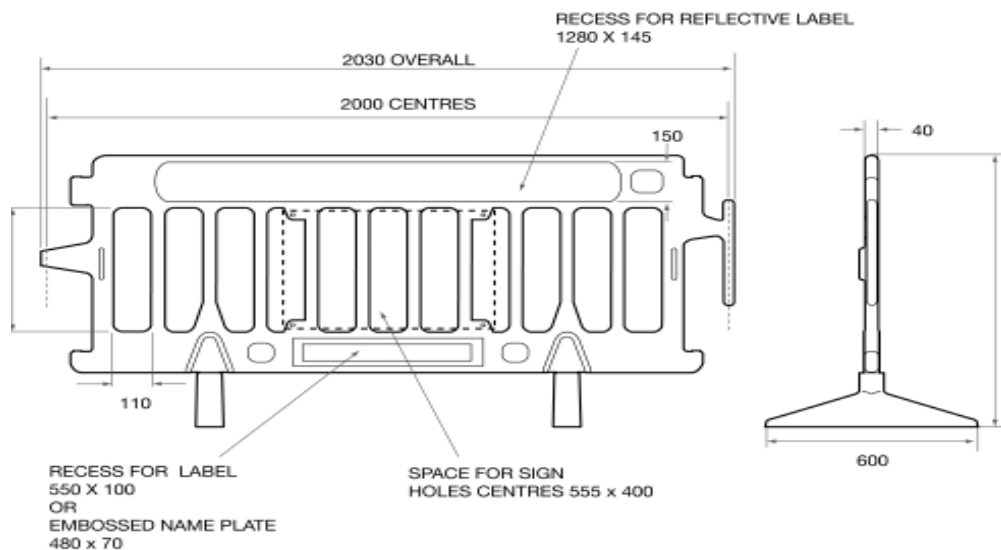

Linking System design creates secure joints even on uneven ground - over kerbs, up slopes and across rough terrain. Unlocked or locked mode configurations prevent unauthorised dismantling.

Complies with **BS 7818** Specification for pedestrian restraint systems making it ideal for event management and pedestrian control usage. Advertising signage and reflective material can be fixed to the front and back.

- ◆ Suited to construction applications around temporary excavations and road works.
- ◆ Can be used with link boards to extend barrier configurations.
- ◆ Blow moulded 1 piece barrier constructed from tough high density polythene.
- ◆ Available in 2m length, Weighs 10 Kg.
- ◆ Designed for secure stacking and easy transportation.
- ◆ Personalisation service available on request.

*Lifting & Handling Solutions for the Construction Industry
Designed & Manufactured in the UK*

Conquip Industrial, Waterbrook Estate, Waterbrook Road, Alton, Hampshire, GU34 2UD. United Kingdom
Telephone: +44 (0) 845 201 5030 Fax: +44 (0) 845 201 5031 E-Mail: sales@conquipindustrial.co.uk